



5800 SE 78th Street, Ocala FL 34472
 Phone: 800-327-3015 Fax 352-245 0726
www.americanpanel.com

Project: ZWN045X6*	QUOTATION:
Location:	Submitted by:
Customer:	DATE: 08/28/2015
Identity #:	For Record By:
Tag:	For Approval Date:

PHYSICAL & ELECTRICAL DATA

	COMPRESSOR		CONNECTIONS (inches)		RECEIVER CAPACITY (90%)	NET WEIGHT	WATER (FPT)	85°F INLET 15° SST	AMBIENT TEMP
	Model No.	HP	Liquid	Suction				7.7 GPM	
	ZS29KAE	4	1/2	7/8	20	265	1/2	3.2 PSI	95°F

POWER SUPPLY	COMPRESSOR		FAN MOTOR			MCA†		MOP‡		Evap. Fan	Defrost Heater
Volts / Ph / Hz	RLA	LRA	QTY	HP	FLA	Air	Elec.	Air	Elec.	Amps	Amps
208-230/3/60	18.4	114				23		40	50	16	70
460/3/60	8.4	58				15		15			

†MCA=Minimum Circuit Ampacity
 ‡MOP = Maximum Overcurrent Protection

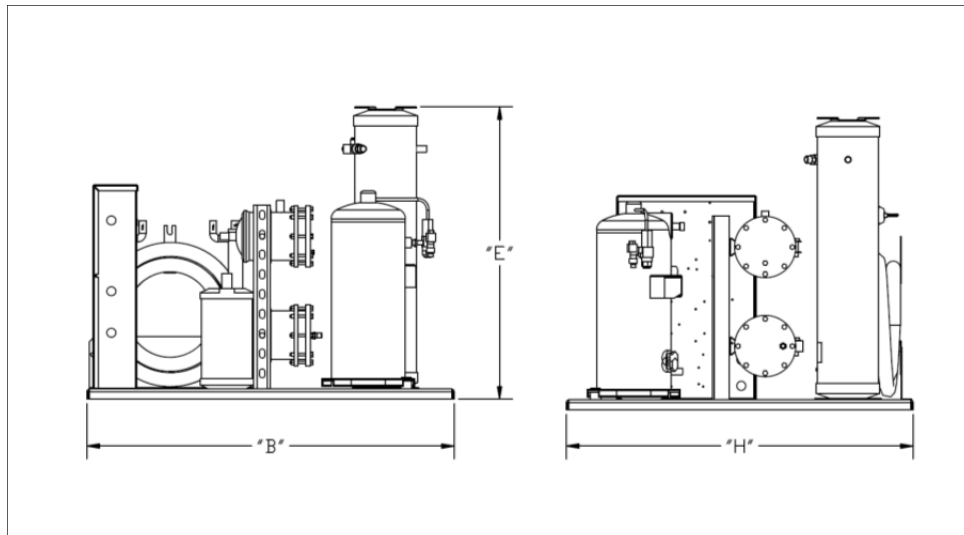

DIMENSIONS (inches)									
A	B	C	D	E	F	G	H	J	
	36			28.625			34		



5800 SE 78th Street, Ocala FL 34472
 Phone: 800-327-3015 Fax 352-245 0726
www.americanpanel.com

DIMENSIONS (inches)						
K	L	M	N	P	R	S

CAPACITY (BTUH)						
40 °F SST	35°F SST	30 °F SST	25 °F SST	20 °F SST	15 °F SST	10°F SST
47860	44180	40620	37280	34020	30950	28160

CAPACITY (BTUH)						
5 °F SST	0 °F SST	-5 °F SST	-10 °F SST	-15 °F SST	-20 °F SST	-25 °F SST
25480	23020	20760	18680	16770	15010	13380

SST = Saturated Suction Temperature

STANDARD FEATURES

- | | |
|--|--|
| <ul style="list-style-type: none"> Construction • Pre-bent tubing • Easy access refrigerant piping • Pressure relief valve • Coaxial condenser coil • More spacious, pre-painted electrical box • 230 volt control (circuit transformer on 460 volt models) • Single electrical connection location • Shipped with dry nitrogen charge • Heavy duty base plate • Plastic conduit on all wiring runs • Replaceable core filter drier with sight glass • Removable electrical box from compressor access from the front • Captive door fasteners | <ul style="list-style-type: none"> Compressor • Scroll compressor • Compressor contactor • Oil pressure switch (where required) • • • Pump down switch • Fixed low pressure switch (adjustable on low temp models) • Fixed high pressure switch |
|--|--|

OPTIONS

Mounted Options:

<input checked="" type="checkbox"/> Power Switch: Compressor Circuit Breakers	<input checked="" type="checkbox"/> Suction Filter Drier: Replaceable Core Filter
<input checked="" type="checkbox"/> Misc: Suction Accumulator	<input checked="" type="checkbox"/> Misc: Dual Pressure Control
<input checked="" type="checkbox"/> Water Regulating Valve	

Ship Loose Options: